

Hill AIRFLEX II Table

Owner's Manual



Hill Laboratories
COMPANY

Quality and Innovation Since 1945.

Congratulations!

And welcome to the Hill Laboratories family.

Hill Laboratories has been making quality a family business since 1945. Your new AIRFLEX II is built on an established Hill tradition of innovation and value. Our reputation rests on the confidence that *your* Hill Table will strengthen this legacy and provide you with solid, reliable service for many years to come.

At Your Service

The Hill Laboratories Guarantee.

Your Hill Laboratories table has been thoroughly tested and inspected before shipment. All parts are guaranteed against defect in materials for one full year from the date of purchase. During this period, any such defect will be remedied by Hill Laboratories or by a factory-authorized repair service at no charge. Tables damaged by mishandling or accident will be repaired at a reasonable charge. All correspondence should be directed to your local dealer, or when this is not possible, to Hill Laboratories directly.

For tables beyond the warranty period, our service technicians are standing by to serve you. They can be reached toll-free at 1-877-445-5020 from 9 am - 5 pm E.S.T., Monday through Friday. After hours, please leave your name, phone number and a brief description of your concern. Your call will be returned promptly the next business day.

We appreciate your business and your confidence in our products. Our aim is to provide you with excellent service and satisfaction for many years to come.



President, Hill Laboratories

Hill Air-Flex Manual

Table of Contents

Product Features

Basic Table Components	1.1
Specifications	1.2

Table Care

Cleaning your Table	2.1
Caution and Symbol Explanation	2.2

Basic Table Operation

Power, Paper Roll and Locks	3.1
Height Pedal	3.2
Touchscreen	3.3
Manual Thoracic Release	3.4
Basic Distraction	3.5
Basic Flexion (Balancing the Patient)	3.6

Using the Rotation Lock

Using the Rotation Feature	4.1
Returning the Rotation Feature to the Horizontal Position	4.2

Using Air-Drops

Thoracic Air-Breakaway	5.1
Drop Selection	5.2

Headpieces

Tilting Headpiece	6.1
Dual Drop Headpiece	6.2
Raised Headpiece	6.3
Cervical Flexion Headpiece	6.4
Translation/CBP Headpiece	6.5

Instructions for the Auto-Flexion Option

The Auto-Flexion Touchscreen	7.1
Treating with Auto-Flex	7.2

Instructions for the Auto-Distraction Option

The Auto-Distraction Touchscreen	8.1
Cervical Auto-Distraction	8.2

Settings and Diagnostics

Settings	9.1
Diagnostics	9.2

Trouble Shooting	Pages 16
-------------------------	----------

Wiring Diagrams	Pages 18-20
------------------------	-------------

Index of Terms	Pages 21-22
-----------------------	-------------

Product Features

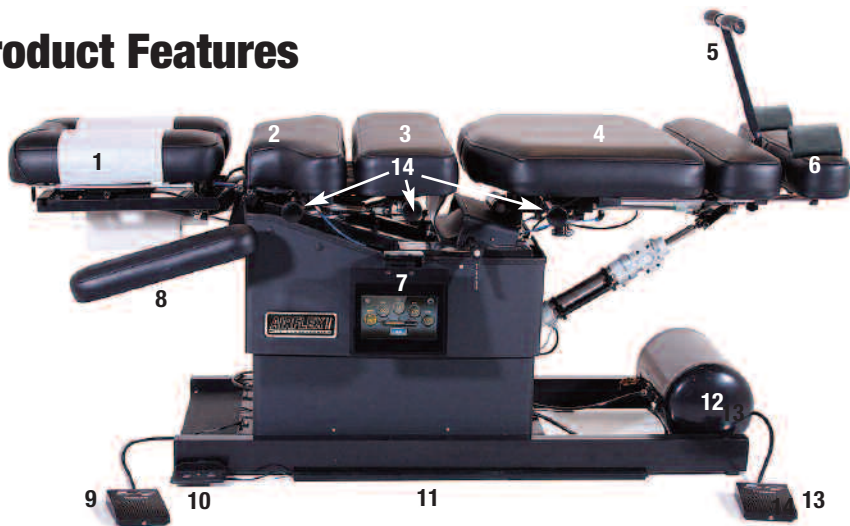

1.1 Basic Table Components and Options

1. Tilting Headpiece. May include several options
2. Thoracic Drop with Thoracic Release/Breakaway
3. Lumbar Drop
4. Pelvic Drop / Lateral Flexion with locking mechanism
5. Removable Flexion Tiller Bar
6. Slide-out Ankle Support with Ankle Harnesses
7. Control Panel Touchscreen
8. Armrest
9. Corded Height Pedal
10. Optional Rocker Foot Pedal
11. Power Foot Strips for activating Air-Drops (optional)
12. Air-Tank
13. Air-Pressure Foot Pedal
14. Drop-Tension Control Knobs

1.2 Specifications

- Electric requirement 110V 60Hz-7A-5 A or 220V-50Hz-4A
Important: See note about using a voltage regulator on page 19
- Lifting capacity - 450 pounds
- Acrylic thermo-plastic base
- Ultra-Cell® foam for comfort and shape retention
- Height Range - 21 $\frac{1}{2}$ "-29" or 22 $\frac{1}{2}$ "-30"
- Shipping weight approximately 250 lbs.
- Standard width 24", optional 22", and 27"

Table Care

2.1 Cleaning your Table

Standard Upholstery - Normal Care and Cleaning

Remove ordinary dirt and smudges with a mild soap and water solution and a clean soft cloth or towel. Dry with a soft lint-free cloth or towel.

Hill Laboratories also offers two excellent products, both available online at Shop.HillLabs.com:

- Hill Leather and Vinyl Cleaner (available in case of 4)
- Protex Disinfectant Spray (available in case of 4 and wipes)

For difficult stains, after using Hill Leather and Vinyl Cleaner, use one of the following non-abrasive cleaners with a soft cloth or damp sponge:

- Formula 409 All-Purpose Cleaner
- Fantastik Spray Cleaner
- Magic Eraser

Caution! Never use bleach, abrasive powder, steel wool, industrial strength or solvent cleaners.

Finesse Upholstery - Normal Care and Cleaning

Remove most ordinary smudges and dirt with a mild soap (like Joy, Dove or Ivory dishwashing liquids) and water solution and a clean soft cloth or towel. Dry with a soft lint-free cloth or towel.

Hill Laboratories also offers two excellent products, both available online at Shop.HillLabs.com:

- Hill Leather and Vinyl Cleaner (available in case of 4)
- Protex Disinfectant Spray (available in case of 4 and wipes)

For more difficult stains like oil, grease, crayon, lipstick, shoe or furniture polish

Use a mild petroleum solvent such as naphtha (lighter fluid) or mineral spirits (paint thinner). Lightly wipe the stain with a clean cloth moistened with solvent. Blot the area and allow to dry.

For Ink: Use one part Wisk detergent and one part rubbing alcohol. Dab lightly with a cloth which has been moistened with the solution—DO NOT RUB! As the ink loosens, blot the area with a dry cloth. Rinse with a cloth dampened in clean water and dry with a soft cloth.

Caution! Never use rubbing alcohol on Finesse except in the limited manner described above.

Cleaning the Touchscreen

To clean your touchscreen, DO NOT use common glass cleaners. Apply a light spray of distilled water or if necessary, a 50/50 mix of white vinegar and distilled water. Use a very soft cloth (cotton or micro-fiber) and apply with gentle pressure. Do not press hard as this can damage the screen.

2.2 Caution and Symbol Explanation

Caution: Children should never be left alone in a room with the table but should always be accompanied by an adult.

Caution: Always unplug the table before performing any maintenance.

Caution: Check table once a year to make sure all internal and external bolts are secure.

Caution: The power cord should be located to avoid risk of tripping or having objects rolled over or placed on it. Damaged cords should be replaced with another of hospital grade.

Caution: Grounding reliability can only be achieved when connected to an equivalent receptacle marked hospital only or hospital grade.

Symbols - Each symbols below is used in your table labeling. An explanation of each is below.



Attention Symbol
consult accompanying
documents



Dangerous Voltage
Symbol



Type BF Applied
Part Symbol



Ground
Symbol



Alternating
Current
Symbol



Don't Touch
Symbol

Basic Table Functions and Operation

3.1 Power, Paper Roll and Locks

Power - Plug your table into any 115 volt grounded outlet (or 230 volt - international). The Power Switch, located just behind the top of the touchscreen (photo 1), controls power to the touchscreen and compressor. It ships in the ON, “pushed in”, position. You may leave on at all times or turn off when not in use. **Note:** The height pedal still works when the switch is off.

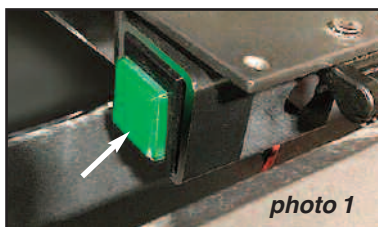

Paper Roll - Feed the paper through the face cutout, around the paper bar (just below the cutout) and over the headpiece as shown. Close the paper cutter located on the side of the headpiece (photo 2) and tear off the excess.



Locks - IMPORTANT! To prevent unwanted movement and potential injury to the patient, it is important that the lateral flexion locking handle is firmly locked, pointing straight down (photo 3) before positioning your patient on the table. If your table has a Thoracic Breakaway, be sure to lock it also before your patient mounts the table (photo 4).

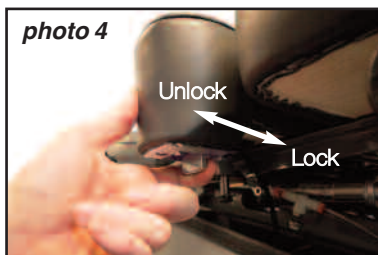

3.2 Height Pedal

The basic AIRFLEX II is equipped with a corded foot pedal (#9 under “Product Features”) which controls the table height. Press the right side of the pedal to elevate; the left side to lower. For tables equipped with a rocker foot pedal (#10, page 2), height may be adjusted from either side of the table.

Auto-Touch Foot Pedal (option)

The Auto-Touch Foot Pedal option maintains upward or downward motion even after releasing the pedal. **To operate:**

- When the table is at minimum height, double-touch the “UP” arrow and release. The table will continue upward until you tap either side of the pedal again.
- When the table is at maximum height, double-touch the “DOWN” arrow

and release. The table will continue downward until you tap either side of the pedal again.

- When the table is at any starting height in between, a single-touch up or down will start and stop the motion.

3.3 Touchscreen

The touchscreen is the virtual command center of your AIRFLEX II for accessing all table controls and preferences. It comes on automatically when the table is plugged in. Section 5 - 9 explain specific functions.

The touchscreen will “sleep” after 15 minutes without activity; touching the screen will “wake it up”.



3.4 Manual Thoracic Release

Thoracic Release

To operate the Thoracic Release, pull the lever towards you while holding the cushion; adjust to the desired depth. Release the lever to lock the cushion.



3.5 Basic Distraction

The following explains how to use the basic distraction feature on the AIRFLEX II. For detailed instruction on Auto-Distraction, see page 13.

1. Remove the Tiller Bar from its bracket between the ankle and pelvic cushion. (see page 2, #5).
2. Place the patient face down on the table with feet extended over the ankle rest.
3. Pull and hold the Slide-Out Ankle Support lock (photo 5) to extend the table length to fit the patient's height.
4. Secure the Ankle Straps around the patient's ankles.
5. Select the 'DISTRACT' (distraction) from the main home screen (photo 6a). This will take you to the Flexion-Distraction Control Panel screen.
6. Select “DISTRACT” (photo 6b) and then use the pressure foot pedal to

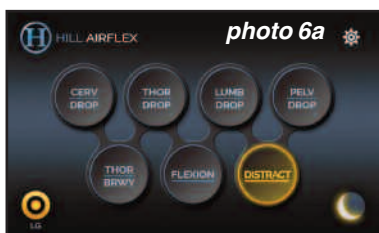

distract the patient. The poundage will display on the center dial.

Note: The speed rate of distraction can be adjusted by opening or closing the air-regulator under the pelvic cushion (photo 7).

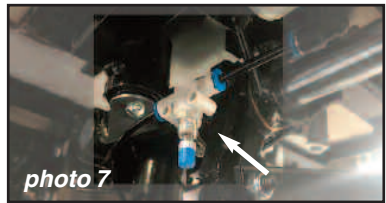

3.6 Basic Flexion (Balancing the Patient)

This section explains how to balance your patient and how to use basic flexion on the AIRFLEX II. For detailed instruction on the Auto-Flexion Feature, see page 11.

Target Touch™

After an initial screen showing the Hill Laboratories logo, you will be taken to the Target Touch™ screen where you will choose a weight range to balance your patient for flexion.

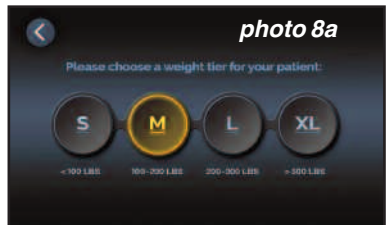

- Choose “S” for Smaller patients, 100 lbs. or less
- Choose “M” for Medium patients, 100-200 lbs.
- Choose “L” for Large patients, 200-300 lbs.
- Choose “XL” for Extra Large patients, 300 lbs. or more

Once selected, the table will automatically preload the flexion cylinder.



Note: You may return to the Target Touch screen anytime during treatment by pressing the target icon (lower left screen).

On the Home screen (photo 8b), select “FLEXION” to enter the Flexion/Distract panel. Press “FLEXION” on the left (see 8c). While holding the foot-end of the table, disengage the Flexion Lock by pressing the blue Lock Icon (top right, photo 8c).



Now the patient is completely supported by air-pressure. Depending on the patient’s weight, you may need to use the Pressure foot pedal to adjust the air-pressure up or down until only a small amount of force is required to flex the patient. If the table does not spring back automatically to a horizontal resting position, slightly increase the pressure.

For lateral movement, unlock the Lateral Locking Handle to the 4 o’clock position (photo 9).

Note: The table can be locked at any angle of flexion at any time during manual flexion by pressing the unlock button in the upper right of the screen (**Caution:** To preserve the



locking mechanism in the flexion cylinder, do not press the icon to lock the cylinder while flexing the patient). You can also lock the lateral axis (with or without locking the flexion axis) by turning the lock handle to the 6 o'clock position.

Using the Rotation Lock

The Rotation option of the AIRFLEX II can be unlocked for free movement or locked at any angle. Unlike the flexion and lateral locks, the rotation lock is lever-controlled. A centering handle (A, photo 10) is also provided to locate and lock the pelvic cushion in the horizontal position.

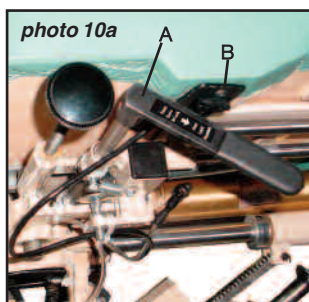

4.1 Using the Rotation Feature

Turn the centering handle to 4 o'clock position (A, photo 10a). Unlock rotation lever by pulling out until it clicks (B, photo 10a) This will allow free movement in rotation. To lock the rotation at any angle, simply push the rotation lever in towards the patient (B, photo 10a).

4.2 Returning the Rotation Feature to the Horizontal Position

1. Unlock lever (B, photo 10b)
2. Manually move the pelvic section to a horizontal position.
3. Engage the centering handle by turning it to the 6 o'clock position (A, 10b).

Note: If the centering handle will not lock, the pelvic cushion is not yet horizontal. Adjust the cushion until the handle locks.

4. Lock the rotation lever (B photo 10b) by pushing it in, towards the table.

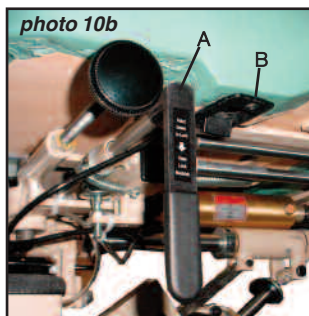

Important! The centering handle alone is not sufficient to secure the rotation function. Be sure to also lock the rotation lever to properly secure rotation.

Using Thoracic Air-Breakaway & Air-Drops

5.1 Thoracic Air-Breakaway

For tables with a Thoracic Air-Breakaway, it is necessary to reduce the air-pressure to zero pounds before treating your patient. Follow these steps:

1. Select the 'THOR BRKY' button on the home screen (photo 11a).

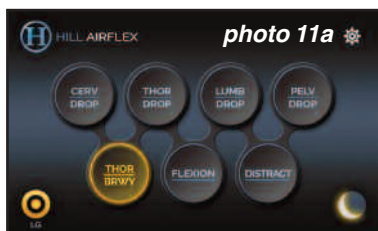

2. Press the left side of the pressure foot pedal to decrease the air-pressure to zero. While supporting the cushion with your hand, unlock the thoracic breakaway switch by pulling toward you until it clicks (photo 4). This will allow the cushion to move freely up and down.



3. Press the right side of the Pressure Pedal (#13, page 2) to increase the air-pressure to your liking. The poundage will show on the touchscreen dial (photo 11b). Push down on the cushion as you add air to test for desired firmness.

4. Lock the cushion at any point by pushing the thoracic lock switch towards the table until it clicks.

Using Air-Drops

5.2 Drop Selection

The Drop Buttons on the home screen (photo 12) activate the table drops.

You may select one or up to four drops simultaneously. Once selected, (each will turn gold), then press the Pressure pedal (or optional foot strips) to activate the drops. They are now ready to release. Once drops are released, press the pedal or foot strip again to immediately reactivate them.



Drop-Tension Control Knobs

The Drop-Tension Knobs are located on the left side of each drop (#14, page 2). Turn the knob clockwise to increase the firmness of the drop—counter clockwise to decrease.

Caution: Do not loosen Tension Knobs too far Adjusting the tension knobs out too far can cause the cervical (and pelvic) drops to malfunction. See “Trouble Shooting” section on page 17 for more detail.

Headpieces

6.1 Tilting Headpiece

All AIRFLEX II models are equipped with a tilting headpiece. The lever for tilting is located under the front of the headpiece (A, photo 13). It controls the angle of tilt positive or negative. Pull the lever to unlock; adjust the angle; release to lock.

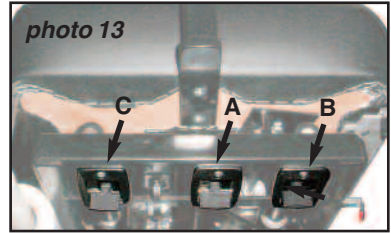

6.2 Dual-Drop Headpiece

The Dual-Drop headpiece contains two drops—a drop-forward motion and a straight-down drop.

Important Note: Before changing any of the settings described in the following section, be sure the headpiece drop is discharged.

Drop-Forward Motion Headpiece

To use the Drop-Forward Motion of the headpiece, the setting lever should remain in the side channel of the setting mechanism as shown in photo 14.

Be sure that the pin locks into the receiver behind it—otherwise, the drop will not work. For a manual drop, push up on the black cocking handle to engage.

For Air-Cervical Drop, see section 5.1.

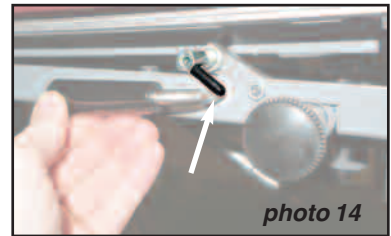

Straight-Down Drop Headpiece

To use the Straight-Down Drop action of the headpiece, pull the black setting lever out and turn it to the left so that it points straight down (photo 15). For a manual drop, push up on the black cocking handle to engage.

For Air-Cervical Drop, see section 5.1).

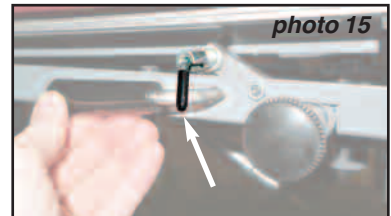

6.3 Raised Headpiece

The Raised Headpiece allows the headpiece to rise up to 5" above the surface of the table. It is controlled by a lever in front of the head cushion (B, photo 13). Pull and hold the switch to adjust to the desired height; release to lock. To lower, apply gentle downward pressure to the thoracic end of the headpiece with one hand while pulling the lever to adjust.

6.4 Cervical Flexion/Distraction

The Cervical Flexion Headpiece includes the raised headpiece feature, occipital strap and the removable tiller bar.

Note: Cervical Flexion, Distraction and Lateral Motion (described below) can be used separately or in combination.

Cervical Flexion

Position the patient as shown in photo 16. Secure the occipital strap using the Velcro® connectors. Use the Tiller Bar to apply flexion.



Cervical Distraction

Important: To use Manual Cervical Distraction you must first unlock the cushion for long axis motion by releasing the red lock pin (shown in photo 17). Pull and turn the lever to the left.

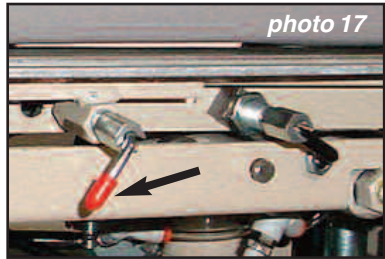

Cervical Lateral Motion

The Cervical Flexion Headpiece includes lateral motion. To use lateral motion, locate the switch as shown in photo 18 (or C, photo 13). Pull the lever toward you to click and unlock. This will allow full-range lateral movement. The headpiece can also be locked at any angle in the lateral range.



6.5 Translation/CBP Headpiece

To use the translation headpiece, loosen the black knob in front of the headpiece by turning it counterclockwise. Push the cushion left or right to the desired position; turn clockwise to tighten the knob.

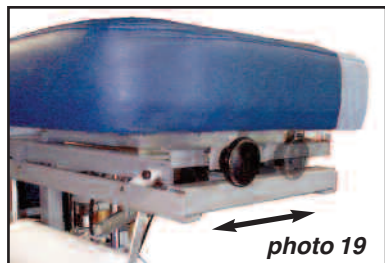

Instructions for the Auto-Flexion Option

Safety Caution: The moveable parts of the Auto-Flex feature can cause severe injury if handled improperly. Children should always be accompanied by an adult when in the room with the AIRFLEX II table.

7.1 The Auto-Flexion Touchscreen

To treat with Auto-Flexion, first balance the patient using Target Touch as described in section 3.6 of this manual. Then, press “AUTO” below the FLEXION Button, as shown to the right in photo 20, to move to the Auto-Flexion Control Panel.



Auto-Flexion Control Panel: Functions Defined

DEPTH - Defines the depth and height (above horizontal) of the flexion stroke from 1-10

SPEED - Defines the speed of the flexion stroke from 1-3

HOLD - Defines the number of seconds the table “holds” at the set depth during each flexion cycle.

REST - Defines the number of seconds the table “rests” horizontally during each flexion cycle.

CYCLES - Defines the number of desired flexion cycles for treatment.

RUN - Starts treatment (photo 21)

STOP - Stops treatment; **PAUSE** - Pauses treatment (photo 22)

SLIDER - Sets the amount for any selected function.

FLEXION LOCK - Press blue Lock Icon to locks flexion at any angle.

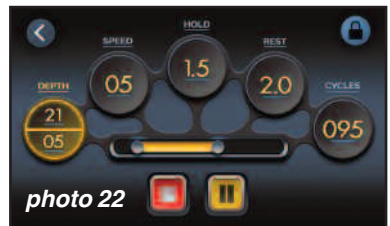
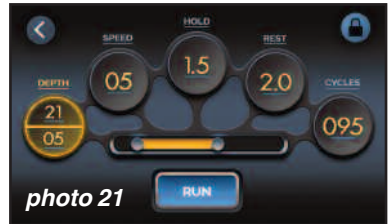

7.2 Treating with Auto-Flex

Important: Before proceeding with Auto-Flexion, read Section 3.6 on ‘Basic Flexion (Balancing the Patient)’.

It is very important that you become familiar with how to balance your patient BEFORE USING the Auto-Flex feature. THE PATIENT MUST BE SUPERVISED AT ALL TIMES DURING OPERATION.

1. Set each of your touchscreen settings (DEPTH, SPEED, HOLD, REST, CYCLES) by touching each button in turn (buttons will turn yellow when selected) and adjusting the slider for the desired setting.

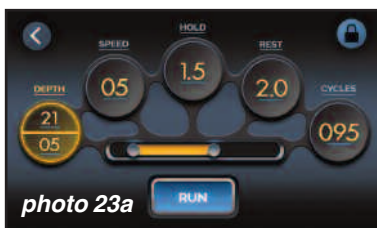

2. With settings selected, press “RUN” to start the treatment. A dialogue will appear (photo 23b); press OK to continue or “CANCEL” to go back to the settings screen. If you pressed “OK”, the RUN button will be replaced by the STOP and PAUSE buttons (23c).



6. Press the yellow “PAUSE” button at any time to pause the treatment or to adjust your settings. The table will return to horizontal. Press PAUSE again to restart the treatment.



7. When the cycle time ends, the table will return to the rest/horizontal position and the flexion lock will lock automatically. It is important to also lock lateral flexion by turning the lateral lock handle (and rotation if so equipped) to the 6 o'clock/locked position (see photo 9 and 10a).

Note: If your patient is already distracted, flexion settings may not need to be as deep. Making a note of your settings for each patient makes it easy to duplicate treatment on subsequent visits.

Emergency Stopping

To immediately stop an Auto-Flexion or Auto-Distract treatment at any time, press the STOP button on the touchscreen



or the patient can stop the treatment immediately with the Stop-Treatment Patient Switch, both shown here.

Instructions for the Auto-Distraction Option

To use Auto-Distraction, first consult section 3.5 of this manual on “Basic Distraction” for details on securing the patient and navigating to the Flexion-Distraction Control Panel screen. **NOTE:** The AIRFLEX II can be locked in any flexion or lateral position during Auto-Distraction.

8.1 The Auto-Distraction Touchscreen

Auto-Distraction functions defined for Lumbar and Cervical:

PULL - Describes the duration of the treatment Pull Cycle in seconds. It is programmable from 5 seconds to 30 seconds. During a treatment, the Pull Cycle will highlight and countdown the seconds remaining in that cycle.

REST - Describes the duration of the treatment Rest Cycle in seconds. It is programmable from 5 to 30 seconds. During a treatment, the Rest Cycle will highlight and countdown the seconds remaining in that cycle.

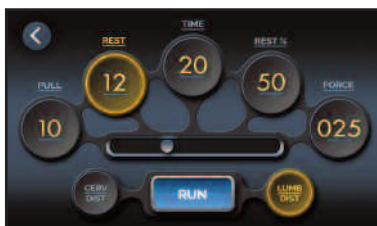

TIME - Describes the duration of the treatment time in minutes. The display will count down once the treatment has begun.

REST% - Rest % is used to calculate the Force during the Rest Cycle. It can be set to either 25% or 50%. For example, with a Force Setting of 40 lbs during the Pull Cycle, setting the Rest % to 25% will administer 10 lbs of Force during the Rest Cycle. A 50% setting yields 20 lbs. during Rest Cycle.

FORCE - The treatment Force is measured in U.S. pounds. It is programmable from 5 lbs-125 lbs for a Lumbar Treatment and 5 lbs–50 lbs for a Cervical Treatment. During a treatment, the Force Setting will show the measured force in real-time.

SLIDER - Sets the amount for any selected function

LUMB DIST - When selected it will turn yellow showing that all settings are now controlling Lumbar Distraction

CERV DIST - When selected it will turn yellow showing that all settings are now controlling Cervical Distraction

RUN: Pressing RUN starts the treatment. The RUN button will be replaced by the STOP and PAUSE buttons while treatment is active.



8.2 Cervical Auto-Distraction

Using Cervical Distraction

Insert the Cradle - Insert the cradle assembly into the receptacle at the end of the headpiece (A, photo 24).

Position the Patient - Gently insert the patient's neck into the cradle support with the insert pad facing the ceiling. Tighten the tension knob until the patient feels a slight inward pressure (A, photo 25). Secure the forehead straps with the Velcro connectors and tilt the headpiece about 5-10° (photo 24). Grasp the patient's ankles and gently pull towards the foot end of the table to ensure that the patient's occipital region rests upon the upper inside ridge of the cradle support (photo 25).

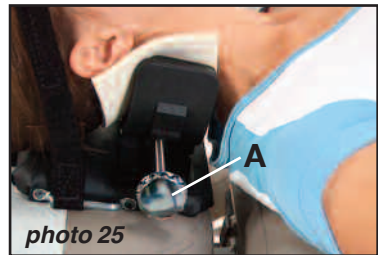
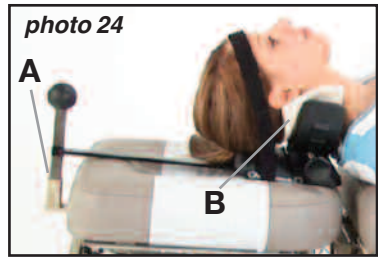

Unlock the Headpiece (Very Important!) - Pull and rotate the red pin located underneath the headpiece cushion by pulling the red handle out and left. This will unlock the headpiece for Auto-Distraction (see photo 17).

Enter Settings - Follow the instructions in section 3.5 of this manual on “Basic Distraction” to navigate to the Flexion-Distraction Control Panel screen. Enter your treatment settings following the same procedure used for Lumbar Distraction (See Section 8.1, “The Auto-Distraction Touchscreen”). Push the blue run button to start the treatment.

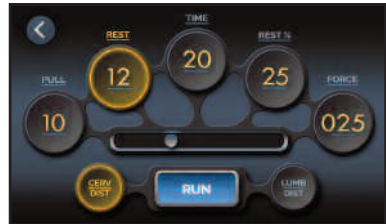

Pausing or Stopping Treatment - Press the yellow “PAUSE” button at any time to pause the treatment or to adjust your settings. The table will return to home position. Press PAUSE again to restart the treatment. Pressing the red STOP button will stop the treatment immediately.

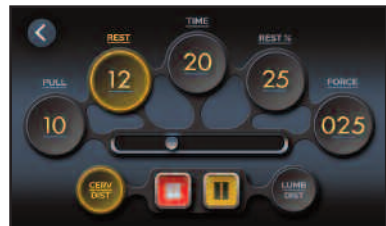

When the cycle time ends, the table will return to the home position.

Emergency Stop - As with Auto-Flex, Emergency Stop can be used at any time by you or your patient. See “Emergency Stopping for Auto-Distraction” under section 7.2.

Settings and Diagnostics

9.1 Settings



The Settings Panel is accessed by pressing the Settings Icon found in the top right corner of the Home Screen.  Settings allow you to set your preferences and access the diagnostics panel for your AIRFLEX II.

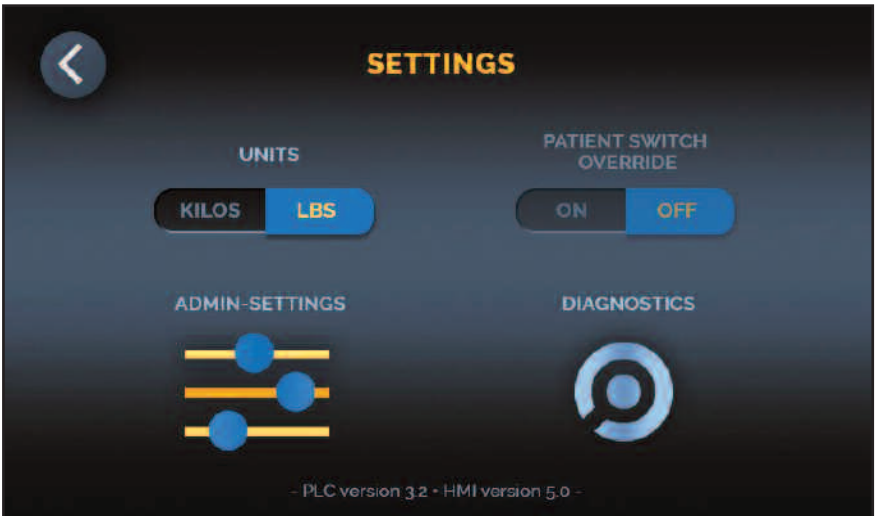

Functions Defined

UNITS - Program measurements may be set for pounds (LBS) or KILOS.

PATIENT SWITCH OVERRIDE - As the name suggests, this feature, when turned on, allows the doctor to override the patient switch....

ADMIN-SETTINGS - These are factory settings only accessible by an authorized technician.

DIAGNOSTICS - Allows testing of key table functions (see next page).

9.2 Diagnostics



The Diagnostic Screen is accessed through the Home Screen, and then by pressing the Diagnostics Icon (left). The Diagnostic screen allows testing of key table functions:

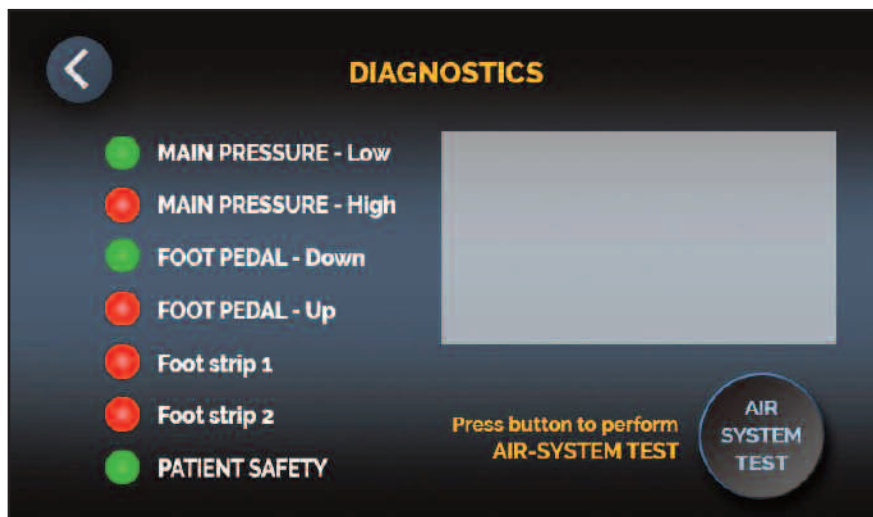

Functions Defined

MAIN PRESSURE - Low/High: These indicate the pressure in the air-tank; tank is full when both are green

FOOT PEDAL - (Down/Up): Tap the down or up arrow of the foot pedal. Respective lights turn green if operating properly

FOOT STRIP - (1 and 2): Tap foot strip 1 or 2. Respective light will turn green if operating properly

PATIENT SAFETY - Press button; light will turn green if operating properly (Auto-features only)

AIR SYSTEM TEST - Press to start test of all air system components. The test results will be detailed in screen when finished.

Maintenance

Regular Maintenance

Your Hill AIRFLEX II is practically maintenance free. There is no lubrication of parts needed.

Trouble Shooting

Problem

**The Pelvic Cushion cocks but does not stay up.
The drop pin has come out of its track.**

To Fix:

1. Loosen the Pelvic Drop Tension Knob enough to rotate the drop pin (see "A" in drawing) so that the cross pin (B) faces and engages the bracket (C) as shown in the photo and drawing below. You may need to use a flat head screw driver to turn the pin from the bottom. Once the pin is turned into the bracket, retighten the Tension Knob.

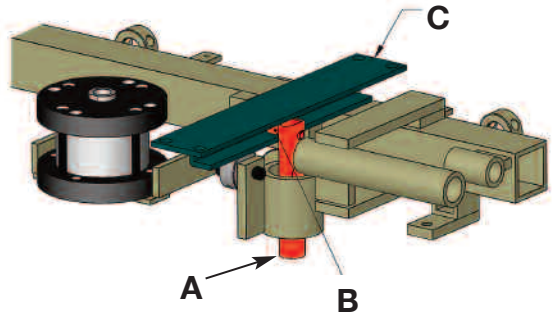
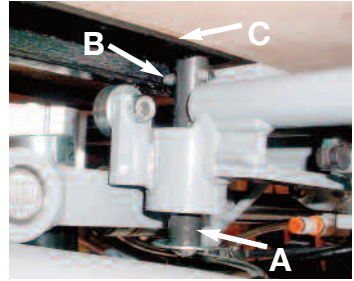

Problem

**The Cervical Cushion cocks up but does not stay up.
The drop pin has come out of its L-bracket.**

To Fix:

1. Loosen the Cervical Drop Tension Knob enough to rotate the drop pin (see "A" in photo) so that the spring pin (B) faces and engages the bracket (C) as shown in the photo. Once the pin is turned into the bracket, retighten the Tension Knob.

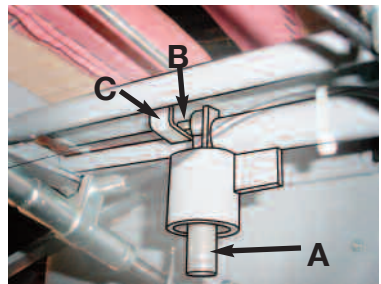

Wiring Diagram - Air Flex, Part 2

CECC Close-up

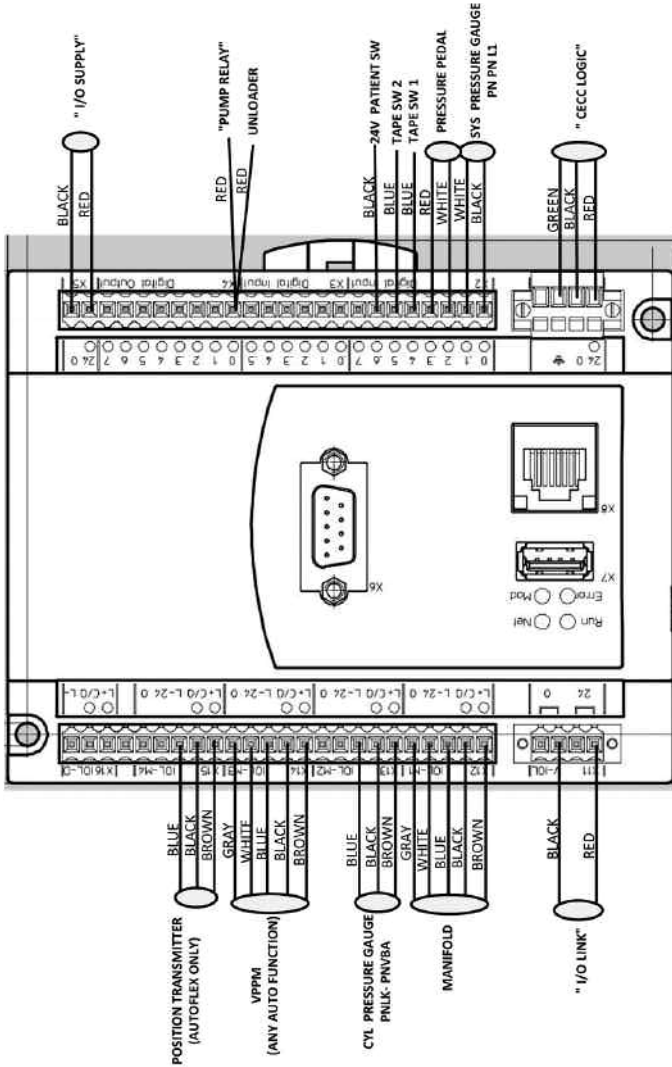

Important:

Air functions on this table are controlled by a circuit board and low voltage valves. Since electrical spikes, surges and undervoltage can be detrimental to electronic components, we recommend protecting your table with an automatic voltage regulator. While a voltage regulator will not guarantee parts against failure, it could save you the cost of parts as well as table downtime.

The APC LE1200 voltage regulator is one example of a device that would provide a basic level of protection.

Wiring Diagram - Air Flex, Part 3

Power Supply Close-up

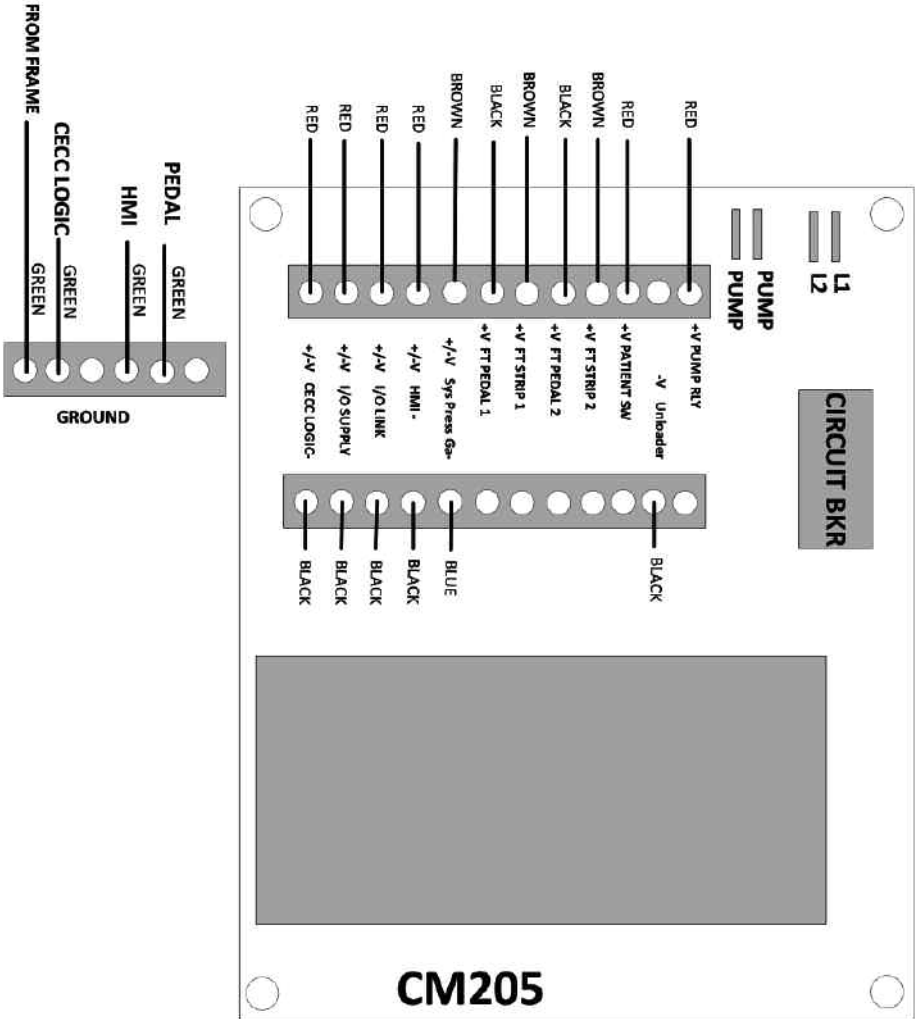

Index

A

- Air-Drops 7, 8
- Air System Test 16
- Ankle Support
 - Adjusting 2, 5
 - Straps 2, 5
- Armrests 2
- Auto-Distracton 13-14
- Auto-Flexion 10-12
- Auto-Touch Foot Pedal 4

B

- Balancing the Patient 6
- Basic Table Components 2

C

- Cervical Distracton 10
- Cervical Flexion (see "Flexion") 10
- Cleaning your table 3
- Cautions and Symbols 3

D

- Diagnostics 16
- Distracton
 - Auto 13-14
 - Basic 5
 - Cervical 10
- Drops
 - Cervical
 - Operating 7-9
 - Not popping up 17
 - Lumbar
 - Operating 8
 - Pelvic
 - Operating 8
 - Not popping up 17
 - Thoracic
 - Operating 8

E

- Electrical specifications 2
- Emergency Stop
 - Patient Switch 12, 14
 - Stop Button 11, 12, 14

F

- Flexion
 - Auto 11-12
 - Basic/Manual 6
 - Cervical 10
- Foot Pedal
 - Auto-Touch 4
 - Corded 2, 4
 - Rocker 2, 4
- Foot Strips 2, 8

H

- Headpiece 2, 4, 9
 - Air-Drop 8
 - CBP/Translation 10
 - Dual-Drop 9
 - Flexion 10
 - Lateral Adjustment 10
 - Raised 9
 - Tilting 9
 - Translation/CBP 10
- Height Range 2
- Height Pedal 4

K

- Knobs (See Tension Control Knobs)

L

- Lateral Adjustment
 - Cervical 10
 - Pelvic 7, 12, 13
- LCD (see "Touchscreen")
- Lifting Capacity 2
- Locking Mechanisms
 - Flexion 11
 - Headpiece 8-10
 - Lateral 2, 4, 6

Index

L (continued)

- Rotation 7
- Thoracic Breakaway 2, 7, 8
- Thoracic Release 4, 5

M

- Maintenance 17
- Manual Flexion (See Flexion)

P

- Paper Roll 4
- Patient Switch (see “Emergency Stop”)
- Pause Treatment 11, 12, 13
- Power Switch 4

R

- Raised Headpiece (See Headpieces)
- Rocker Foot Pedal (See Foot Pedal)
- Rotation
 - Locking 7
 - Operating 7

S

- Service and Support See intro, “At Your Service”
- Settings 15
- Specifications 2
- Speed Setting 11, 12
- Stop Button (see “Emergency Stop”)
- Surge Protection 19

T

- Table Components 4
- Target Touch 6
- Tension Control Knobs 2, 8, 14
- Tiller Bar 2, 5, 10
- Thoracic Breakaway 2, 7, 8
- Thoracic Drop (see “Drops”)
- Thoracic Release 4, 5

Touchscreen

- Cleaning 3
- Functions and Operation 6, 11-16

Trouble Shooting 17

W

- Warranty See intro, “At Your Service”
- Wiring diagrams 18 - 20



Additional service needed?

Contact your local dealer or reach us directly:

Phone: 1-877-445-5020

Fax: 610-647-6297

Email: Support@HillLabs.com

Technicians are available 9 am - 4 pm E.S.T., Monday - Friday.



Hill Laboratories
COMPANY

3 N. Bacton Hill Road, Frazer, PA 19355 • www.HillLabs.com
610-644-2867 • 1-877-445-5020 • Fax 610-647-6297