

Hill Counterstrain

Treatment Table



Hill Laboratories
COMPANY

REFERENCE MANUAL

Congratulations!

And welcome to the Hill Laboratories family

HillLaboratories Company has been making

quality a family business since 1945.

Your Hill Counterstrain Table is built in a tradition of

innovation and value that Hill Laboratories products

have become known for.

Our good name rests on the confidence that

your Hill Chair will provide you with solid, reliable service

for many years to come.

At Your Service

The Hill Laboratories Guarantee

Your Hill Laboratories Counterstrain has been thoroughly tested and inspected before shipment. All parts are guaranteed against defect in materials for one full year from date of purchase. During this period, any such defect will be remedied by Hill Laboratories or by a factory-authorized repair service without charge.

Tables damaged by mishandling or accident will be repaired at a reasonable charge.

All correspondence should be directed to your local dealer, or when this is not possible, to Hill Laboratories directly.

We appreciate your business and your confidence in our product. Our aim is to provide you with excellent service and satisfaction for many years to come.

President of Hill Laboratories Company

Table Serial Number _____

Ready for use

Your Hill Counterstrain comes ready to plug into any 115 v~ outlet.



IMPORTANT: This table should be used for positioning only and is not designed for continual motion techniques.

Specifications

Table Rating

250 lbs. / Static Tested at 4x Rating

Height Range - 22"-35"

Standard Width - 24"

Length Reclined - 78"

Table Base Skirting

Acrylic thermo-plastic

Foam

Ultra-Cell® for comfort and shape retention

Shipping Weight

Approximately 250 lbs

Electric Requirements

115 v~, 60 Hz., 10 A (2 motor), where specified -
230 v~, 50 Hz.

Note: Grounding reliability can only be achieved when the equipment is connected to an equivalent receptacle marked hospital only or hospital grade. There is no EMI concern related to the safe operation of this table.

Transportation and Storage Conditions

Ambient Temperature Range:

-30°C to +60°C (-22°F to 140°F)

Relative Humidity

0% to 90% (non-condensing)

Table Care

Cleaning Your Table

Your Hill Table comes upholstered in a highly durable vinyl material. Its appearance is guarded by Prefixx™ brand protective finish. Your upholstery may be cleaned with the Hill Laboratories Vinyl Cleaner or any non-abrasive household detergent without change to surface luster. Stubborn stains can be cleaned with most common solvent cleaners such as naphtha (lighter fluid), rubbing alcohol (IPA type), toluene, Coleman gas, turpentine (paint thinner), and nail polish remover (50/50 mixture of acetone and water) with no change to surface luster or color. One hundred percent acetone can also be used for short periods but it is suggested that it first be tested on an inconspicuous area of the table.

Caution: These solvents are highly flammable; exercise proper care when cleaning with these materials and do not use near open flame or intense heat. Wear rubber gloves during all cleaning activities. When cleaning other parts of your table (besides upholstery) use only nonabrasive household detergents and water.

Cautions and Symbol Explanation

Caution: Be sure to unplug your table before performing any maintenance on the table.

Caution: The table should be checked once a year to make sure all internal and external bolts are secure.

Caution: The table should be in its lowest height position when not attended.

Caution: In case of power outage, the table will rely on the generator back-up of the facility where the table is installed for powering the table to its lowest position.

Caution: The power cord shall be located to avoid objects being rolled over or placed on top of it and also to avoid people tripping over it. Damaged cords should be replaced with another of hospital grade.

Caution: Grounding reliability can only be achieved when the equipment is connected to an equivalent receptacle marked hospital only or hospital grade.

Symbols - Each of the symbols below are used in your product labeling. An explanation of each is below.



Attention Symbol
consult accompanying
documents

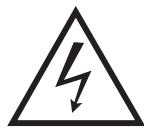

**Dangerous Voltage
Symbol**



**Type BF Applied
Part Symbol**



**Ground
Symbol**



**Alternating Current
Symbol**

Table Features

Instructions for Adjusting Table Sections with the Mechlok® Release Switch

1. Locate the Mechlok Switch on the cushion you want to move (see “Ready For Use” Page)
2. Pull the switch handle towards you and hold it while you move the table section to the desired position.
3. Release the switch handle at any point to lock the cushion in place.



Rocker Foot Pedal

The optional Rocker Foot Pedal operates the height of the table from either side of the table base. Press the right side of the pedal for “UP” and the left side for “DOWN”. The pedal will return to the neutral position when released.



Wiring Diagrams

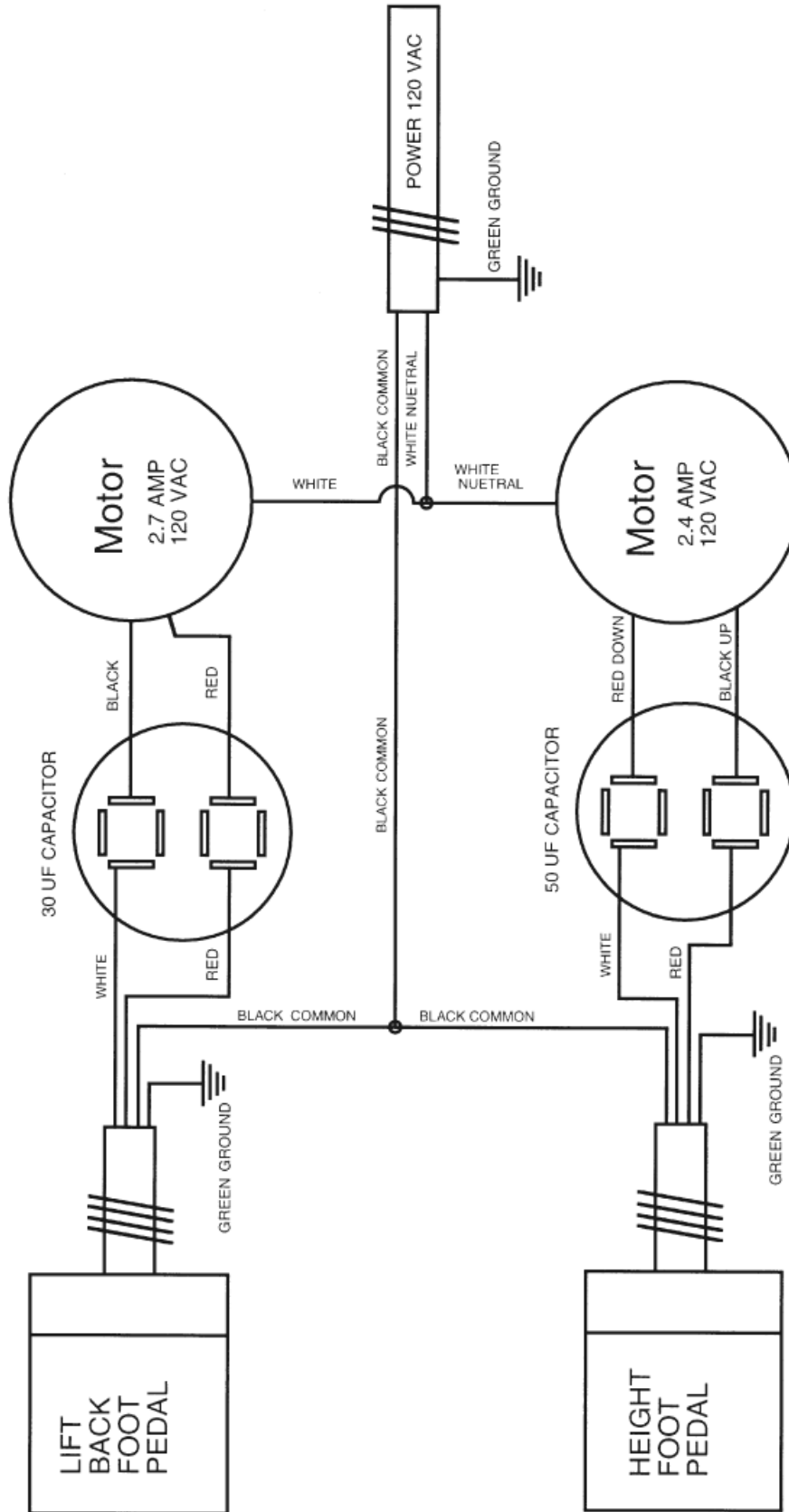

Tables Manufactured by Hill Laboratories



Anatomotor
Massage w/Traction



90C



Air90C



Air-Flex
w/4 Drops



Hi-Lo



HA90



HA90 Lift Back



Mat Table



PT Mobilization



Rath Mechanical
McKenzie Technique



Repex Table
McKenzie Technique



PT Tilting



HA90E



90MD



90D Dermatology
Chair



90W Wound Care Chair



Podiatry Model



Counterstrain
(multi-positional)



HA90V Tilt
Vascular/Diagnostic



Posture Angel™
Active Rehab System



Additional service needed?

Contact your local dealer or reach us directly:

See contact information below or email: Support@HillLabs.com

Technicians are available 9 am - 4 pm E.S.T., Monday - Friday.

